

FlexiSeal® Rotary Seals

Introduction

Catalog EPS 5340/USA

Contents

Engineering	7-2
Materials	7-4
Product Offering	7-5
FlexiSeal Rotary	
FC and FH Profiles — Inch/Fractional	7-9
FC and FH Profiles — Metric	7-16
FF Profiles — Flanged Inch/Fractional	7-18
FF Profiles — Flanged Metric	7-26



Rotary FlexiSeal is the answer for many radial applications.

The Rotary FlexiSeal should be used when speeds are relatively low (<1000 sfpm) and pressures are high (up to 10,000 psi). FlexiLip™ and FlexiCase™ profiles should be used when pressures are low and speeds high. Rotary FlexiSeals feature either a flanged design or an O-ring on the OD to keep the seal fixed in the bore as the shaft rotates. The O-ring can either be centered along the OD or be located in the heel of the seal. Virtually any O-ring material can be supplied with a custom rotary FlexiSeal, but a fluorocarbon material is standard.



Rotary FlexiSeal

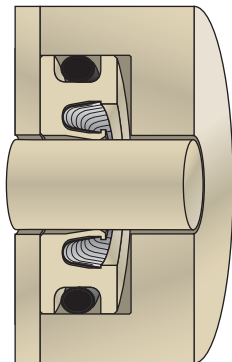

Rotary Application

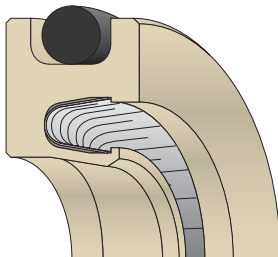

**Chamfered ID, O-Ring OD
Rotary FlexiSeal**

Applications

Radial applications with extreme conditions that involve lower speeds and higher pressures, for which the Rotary FlexiSeal is best suited, include:

- Compressors
- Cryogenics
- FDA Clean Grade
- Jet Engines
- Hydraulic Cylinders
- Pressure Washers
- Robotics
- Rotary Unions
- Steering Cylinders
- Swivels
- Vapor Recovery Systems
- Many more

Markets

Since the FlexiSeal solves problems along several parameters, it can be found in virtually every market including:

- Aerospace
- Automotive
- Chemical Process
- Appliances
- Electronic
- Food & Beverage
- Heavy Machinery
- Hydraulic
- Machine Tools
- Marine
- Medical
- Military
- Oil & Gas
- Pharmaceutical
- Semiconductor



01/15/06



Choosing the Right Design

While choosing the right Rotary FlexiSeal for your application, you need to consider:

- Pressure
- Shaft Velocity
- Lubrication
- Shaft Misalignment
- Shaft Runout
- Shaft Hardness
- Shaft Surface Finish
- Different Spring Choices
- Lip Shapes
- Shaft Lead

Pressure and Shaft Velocity

Unlike reciprocating applications, seals ride on a rotating shaft in only one small area where dynamic forces and energy are concentrated. For a guide to aid in the choice of seal profile and material for optimum seal life, see **Page 2-17**.

Lubrication

While FlexiSeals made of PTFE have a natural lubricity and can be used in unlubricated applications, a film of lubricant between the seal lip and the shaft reduces seal wear and frictional heat generation, makes higher surface speeds possible, and helps prevent the seal from wearing a groove in the shaft.

Shaft Misalignment and Runout

Applications with rotating shafts may develop problems associated with shaft misalignment. Because rotary FlexiSeals are spring-loaded, they normally handle runout and eccentricity better than FlexiLip and FlexiCase seals. For more information about problems with eccentricity and runout, see **Page 2-19**.

Shaft Hardness and Surface Finish

It is critical to match the right surface roughness with the media being sealed, especially when the surface is hardened and the original finish will take some time to break in. See **Table 7-1** for recommendations and **Pages 2-9** and **2-10** for a more general discussion on the topic.

Table 7-1. Surface Roughness, R_a

Media Being Sealed	Dynamic Surfaces		Static Surfaces	
	μ inch	μ m	μ inch	μ m
Cryogenics	6 max.	0.15 max.	8 max.	0.2 max.
Helium Gas Hydrogen Gas Freon	8 max.	0.2 max.	12 max.	0.3 max.
Air Nitrogen Gas Argon Natural Gas Fuel (Aircraft and Automotive)	12 max.	0.3 max.	16 max.	0.4 max.
Water Hydraulic Oil Crude Oil Sealants	12 max.	0.3 max.	32 max.	0.8 max.

Spring Choices

Rotary FlexiSeals are available with two different spring designs to energize the jacket: V-shaped cantilever springs (V Series) and canted-coil springs (C Series). The FFN-H flanged design included in this section uses the helical spring (H Series) and should only be used for static or very slow rotary. Details on spring features can be found on **Page 2-12**.

7

02/15/08



Table 7-2. Recommended Applications for FlexiSeal Rotary Springs

V Series	C Series	H Series
rotary shafts <100 sfpm	rotary shafts <1000 sfpm	flanged rotary seals
wide tolerance and misaligned glands	wide tolerance and misaligned glands	static or very slow dynamic seals (<50 sfpm)
abrasive media (when scraper lip is designated)	friction critical and very small diameter applications	when sealability is critical
dynamic applications to 450 °F	dynamic applications to 450 °F	applications below -100 °F

Lip Shapes

Rotary FlexiSeal profiles can be optimized by changing their lip shapes. Chamfered lips maximize sealability while minimizing friction. Scraper lips prevent particles from accumulating at the lip, which makes wash-downs more effective.

Shaft Machine Lead

To avoid pumping fluid under the seal lip, the lead from machining needs to be kept to less than 0.05 degrees. More on machine lead on **Page 2-20**.



02/15/08



FlexiSeal® Rotary Seals

Materials

Catalog EPS 5340/USA

Common Materials Used in this Product

The most popular PTFE fillers used for FlexiSeal Rotary products are carbon fiber, graphite, Ryton®*/carbon and Ryton/carbon/TFM. PTFE is also popular for these products without any filler (virgin PTFE).



A number of other fillers are used in combination with PTFE, and non-PTFE compounds are available. More information on these materials and their properties is available in **Tab 3**. For best results consult the EPS Division PTFE Application Engineering team at (801) 972-3000.

* Ryton is a registered trademark of Chevron Phillips Chemical Company.

0502 — Carbon Fiber Filled

Carbon fiber lowers creep, increases flex and compressive modulus and raises hardness. Coefficient of thermal expansion is lowered and thermal conductivity is higher for compounds of carbon fiber filled PTFE. Ideal for automotive applications in shock absorbers and water pumps.

0602 — Ryton/Carbon Filled

Ryton/Carbon filled PTFE features improved surface lubricity and abrasion resistance. It should be used only on shafts hardened to 60 Rc or more.

0301 — Graphite Filled

Graphite filled PTFE has extremely low coefficient of friction due to the low friction characteristics of graphite. Graphite is chemically inert. Graphite imparts excellent wear properties and high PV to PTFE.

0601 — Aromatic Polyester Filled

Aromatic Polyester offers excellent high temperature capabilities and excellent wear resistance against soft, dynamic surfaces. Aromatic polyester is not recommended for sealing applications involving steam.

0203 — Fiberglass Filled

Glass fiber is the most common filler with a positive impact on creep performance of PTFE. Glass fiber adds wear resistance and offers good compression strength.

7

01/15/06



FlexiSeal® Rotary Seals

Product Offering

Catalog EPS 5340/USA

Decision Tree

Medium to High Speed Rotary FlexiSeal

The decision trees in this guide are to be used as an engineering guide only. Often several other parameters must be considered to optimize seal design. Contact Parker's PTFE Engineering Team for confirmation of your choice or further recommendations. Parker also recommends that any seal be tested in the application conditions before releasing for production.

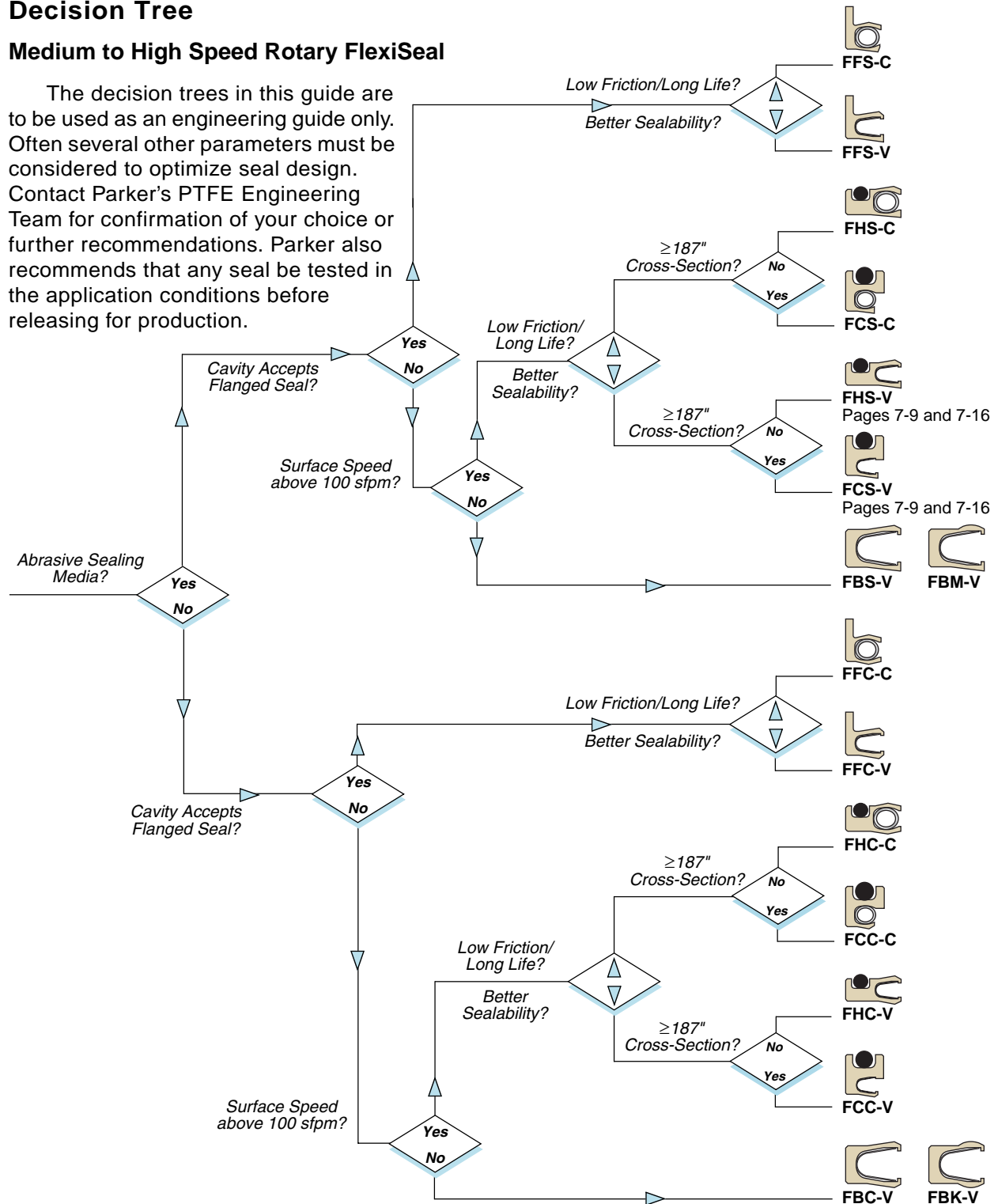

01/15/07



Part Number Nomenclature — FlexiSeal Rotary

Table 7-3. FlexiSeal Rotary Part Number Nomenclature

English

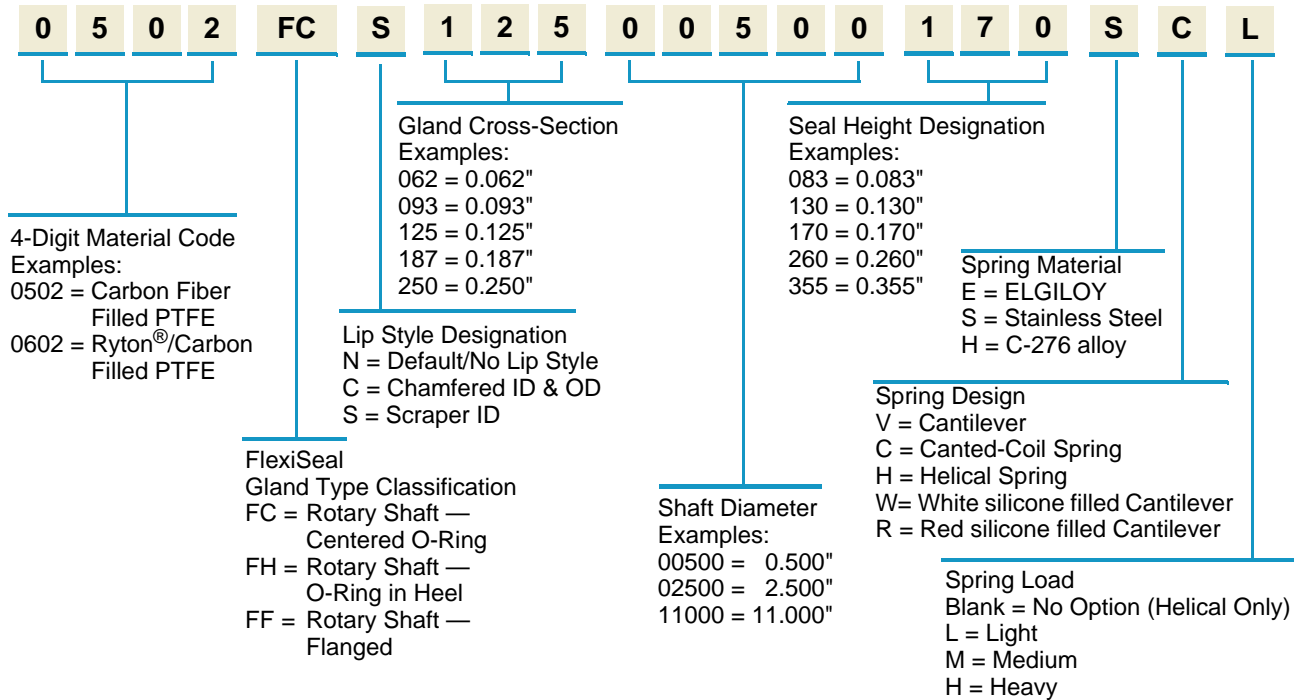



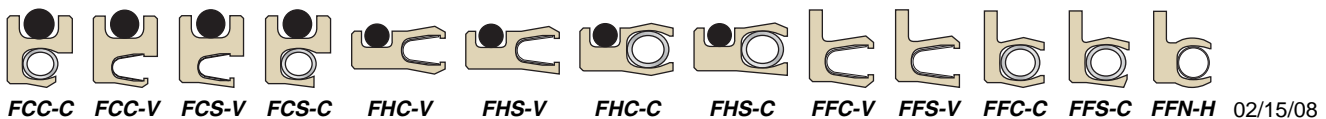
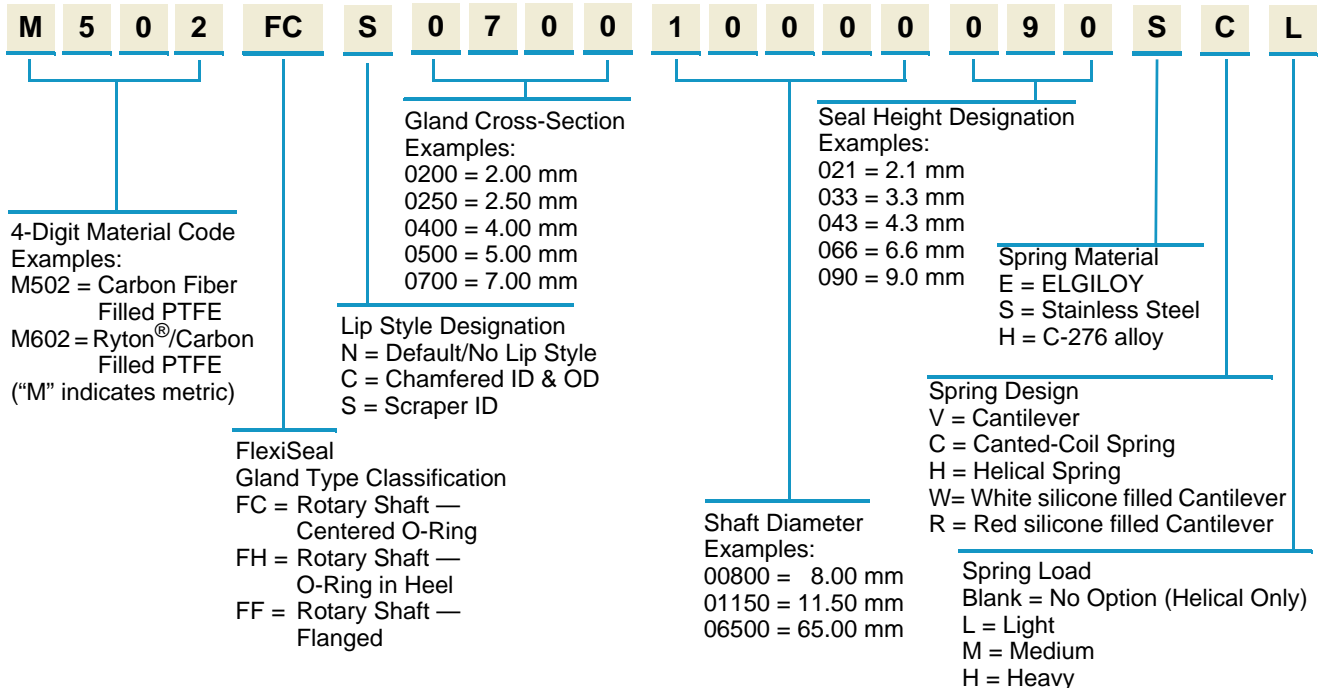



Metric



Profiles

Table 7-4. Product Profiles





Profile	Features	Recommended Applications	Available as Standard in High Pressure Extended Heel (up to 10,000 psi)	Friction Rating	Low Pressure Sealability	Good in Abrasive Media	Max. Rotary Surface Speed (in sfpm)	Gland Dimension Table Location	Available in Mil-G-5514
FCC-V 	O-Ring Centered in OD, Chamfered ID, Cantilever Spring	Optimum sealability. Available in 187 cross-section and higher.	Yes	Medium	Very Good	No	1000	Pages 7-9, 7-16	No
FCS-V 	O-Ring Centered in OD, Scraper ID, Cantilever Spring	Minimizes contamination threat. Available in 187 cross-section and higher.	Yes	Medium	Very Good	Yes	1000	Pages 7-9, 7-16	No
FCC-C 	O-Ring Centered in OD, Chamfered ID, Canted-Coil Spring	Reduced friction and sealability. Available in 187 cross-section and higher.	Yes	Very Low	Good	No	1000	Pages 7-9, 7-16	No
FCS-C 	O-Ring Centered in OD, Scraper ID, Canted-Coil Spring	Low friction with contamination resistance. Available in 187 cross-section and higher.	Yes	Low	Good	Yes	1000	Pages 7-9, 7-16	No
FHC-V 	O-Ring in Heel OD, Chamfered ID, Cantilever Spring	Optimum sealability. Available in extended heel option only.	Yes	Medium	Very Good	No	1000	Pages 7-9, 7-16	No
FHS-V 	O-Ring in Heel OD, Scraper ID, Cantilever Spring	Minimizes contamination threat. Available in extended heel option only.	Yes	Medium	Very Good	Yes	1000	Pages 7-9, 7-16	No



01/15/07

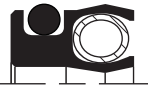

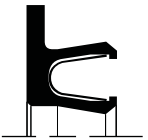
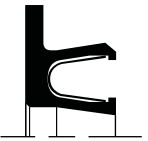
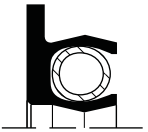
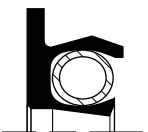
Table 7-4. Product Profiles (Continued)

Profile	Features	Recommended Applications	Available as Standard in High Pressure Extended Heel (up to 10,000 psi)	Friction Rating	Low Pressure Sealability	Good in Abrasive Media	Max. Rotary Surface Speed (in sfpm)	Gland Dimension Table Location	Available in Mil-G-5514
FHC-C 	O-Ring in Heel OD, Chamfered ID, Canted-Coil Spring	Reduced friction and sealability. Available in extended heel option only.	Yes	Very Low	Good	No	1000	Pages 7-9, 7-16	No
FHS-C 	O-Ring in Heel OD, Scraper ID, Canted-Coil Spring	Low friction with contamination resistance. Available in extended heel option only.	Yes	Low	Good	Yes	1000	Pages 7-9, 7-16	No
FFC-V 	Flanged Heel OD, Chamfered ID, Cantilever Spring	Optimum sealability. Premium bore retention.	No	Medium	Very Good	No	1500	Pages 7-18, 7-26	No
FFS-V 	Flanged Heel OD, Scraper ID, Cantilever Spring	Minimizes contamination threat. Premium bore retention.	No	Medium	Very Good	Yes	1500	Pages 7-18, 7-26	No
FFC-C 	Flanged Heel OD, Chamfered ID, Canted-Coil Spring	Reduced friction and sealability. Premium bore retention.	No	Very Low	Good	No	1500	Pages 7-18, 7-26	No
FFS-C 	Flanged Heel OD, Scraper ID, Canted-Coil Spring	Low friction with contamination resistance. Premium bore retention.	No	Low	Good	Yes	1500	Pages 7-18, 7-26	No
FFN-H 	Flanged Heel OD, Rounded ID, Helical Spring	Static or intermittent rotary only. High sealability and friction.	No	High	Excellent	No	50	Pages 7-18, 7-26	No

7

01/15/06



FlexiSeal® Rotary Seals

FC and FH Profiles — Inch/Fractional

Catalog EPS 5340/USA

FC and FH Profiles

FC FlexiSeal Rotary Shaft, Centered O-Ring profiles and FH FlexiSeal Rotary Shaft, O-Ring in Heel profiles are available in the Industrial Inch/Fractional and Metric sizes on the following pages.

Design Considerations

- Hardware Configurations/Installation, see **Page 2-3**
- Surface Finish and Hardness, see **Page 2-9**
- Extrusion Gaps and High Pressure, see **Page 2-10**
- Spring Choices, see **Page 2-12**
- Lip Shapes, see **Page 2-16**
- Rotary Seal Considerations, see **Page 2-17**
- Shaft Misalignment Issues, see **Page 2-19**

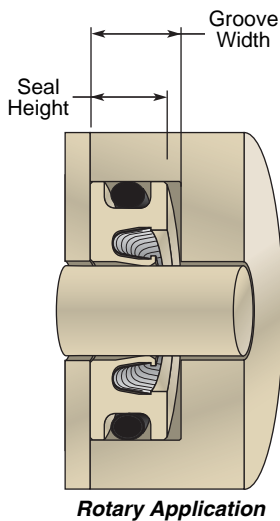

Table 7-5. Seal Height Callouts

Radial Cross-Section	Std. FC Seal Height Callout	Std. FH Seal Height Callout
093	N/A	195
125	N/A	265
187	260	345
250	355	425

Note: FH profiles are available in extended heel only.

Part Number Example

Table 7-6. FC and FH Inch/Fractional Part Number

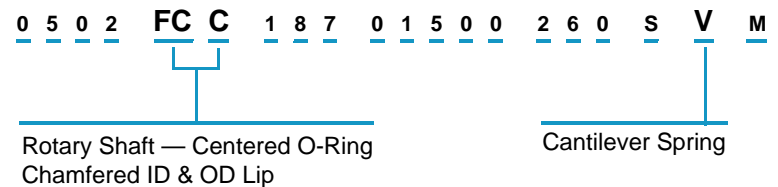

Extended Heel Option

All part numbers on the following pages call for the standard seal height for pressures below 3000 psi.

The heel of a FlexiSeal can be extended to increase extrusion resistance simply by changing the seal height callout in the part number.

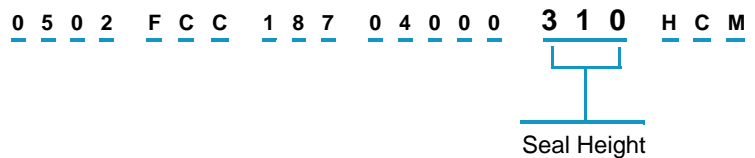
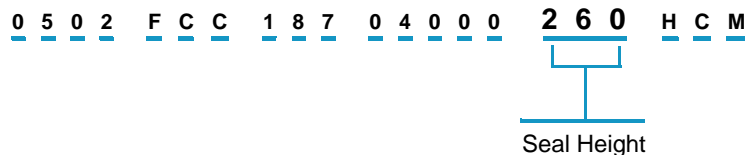

01/15/07



Gland Dimensions — FC and FH Profiles

Table 7-7. FC and FH Inch/Fractional Gland Dimensions

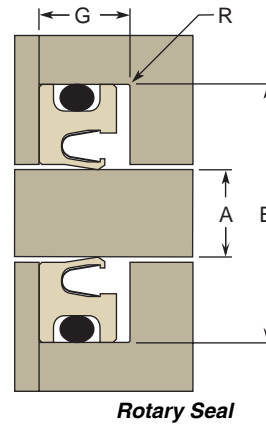

Each of these FlexiSeal profiles were designed to fit into either the Inch/Fractional glands on the following pages or the Metric glands on **Page 7-16**.

FC part numbers are available only in 187 (3/16") cross-section and higher.

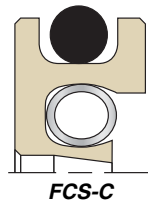
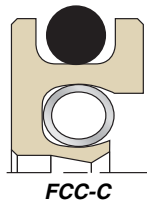
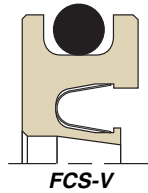
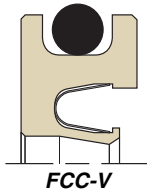

FH part numbers are available in extended heel only.

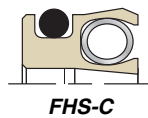
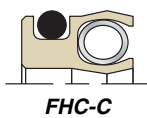
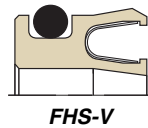
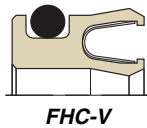

7

02/15/08



Table 7-7. FC and FH Inch/Fractional Gland Dimensions (Continued)

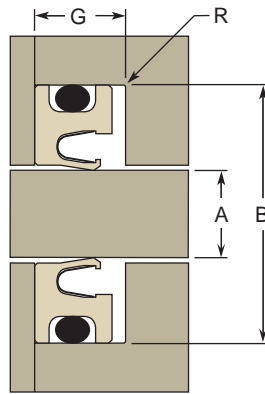

Rotary Seal

Dash #	A Shaft Diameter	B Groove Diameter	Part Number
--------	------------------	-------------------	-------------

R = 0.010" max. radius

G for FH Seal groove = 0.210/0.220" (195 callout)

	+0.001/-0.002	+0.002/-0.000	
-106	0.187	0.375	xxxxFHx09300187195xxx
-107	0.219	0.406	xxxxFHx09300219195xxx
-108	0.250	0.437	xxxxFHx09300250195xxx
-109	0.312	0.500	xxxxFHx09300312195xxx
-110	0.375	0.562	xxxxFHx09300375195xxx
-111	0.437	0.625	xxxxFHx09300437195xxx
-112	0.500	0.687	xxxxFHx09300500195xxx
-113	0.562	0.750	xxxxFHx09300562195xxx
-114	0.625	0.812	xxxxFHx09300625195xxx
-115	0.687	0.875	xxxxFHx09300687195xxx
-116	0.750	0.937	xxxxFHx09300750195xxx
-117	0.812	1.000	xxxxFHx09300812195xxx
-118	0.875	1.062	xxxxFHx09300875195xxx
-119	0.937	1.125	xxxxFHx09300937195xxx
-120	1.000	1.187	xxxxFHx09301000195xxx
-121	1.062	1.250	xxxxFHx09301062195xxx

Dash #	A Shaft Diameter	B Groove Diameter	Part Number
-122	1.125	1.312	xxxxFHx09301125195xxx
-123	1.187	1.375	xxxxFHx09301187195xxx
-124	1.250	1.437	xxxxFHx09301250195xxx
-125	1.312	1.500	xxxxFHx09301312195xxx
-126	1.375	1.562	xxxxFHx09301375195xxx
-127	1.437	1.625	xxxxFHx09301437195xxx
-128	1.500	1.687	xxxxFHx09301500195xxx
-129	1.562	1.750	xxxxFHx09301562195xxx
-130	1.625	1.812	xxxxFHx09301625195xxx
-131	1.687	1.875	xxxxFHx09301687195xxx
-132	1.750	1.937	xxxxFHx09301750195xxx
-133	1.812	2.000	xxxxFHx09301812195xxx
-134	1.875	2.062	xxxxFHx09301875195xxx
-135	1.937	2.125	xxxxFHx09301937195xxx
-136	2.000	2.187	xxxxFHx09302000195xxx
-137	2.062	2.250	xxxxFHx09302062195xxx
-138	2.125	2.312	xxxxFHx09302125195xxx
-139	2.187	2.375	xxxxFHx09302187195xxx
-140	2.250	2.437	xxxxFHx09302250195xxx
-141	2.312	2.500	xxxxFHx09302312195xxx
-142	2.375	2.562	xxxxFHx09302375195xxx
-143	2.437	2.625	xxxxFHx09302437195xxx
-144	2.500	2.687	xxxxFHx09302500195xxx
-145	2.562	2.750	xxxxFHx09302562195xxx
-146	2.625	2.812	xxxxFHx09302625195xxx
-147	2.687	2.875	xxxxFHx09302687195xxx
-148	2.750	2.937	xxxxFHx09302750195xxx
-149	2.812	3.000	xxxxFHx09302812195xxx
-150	2.875	3.062	xxxxFHx09302875195xxx
-151	3.000	3.187	xxxxFHx09303000195xxx
-152	3.250	3.437	xxxxFHx09303250195xxx
-153	3.500	3.687	xxxxFHx09303500195xxx
-154	3.750	3.937	xxxxFHx09303750195xxx
-155	4.000	4.187	xxxxFHx09304000195xxx
-156	4.250	4.437	xxxxFHx09304250195xxx
-157	4.500	4.687	xxxxFHx09304500195xxx



02/15/08



Table 7-7. FC and FH Inch/Fractional Gland Dimensions (Continued)

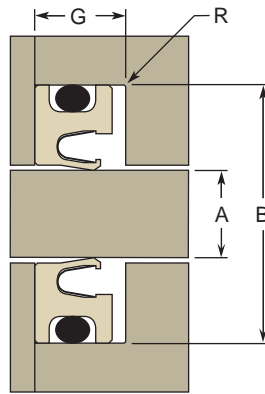

Rotary Seal

Dash #	A Shaft Diameter	B Groove Diameter	Part Number
--------	------------------	-------------------	-------------

R = 0.010" max. radius

G for FH Seal groove = 0.210/0.220" (195 callout)

	+0.000/ -0.002	+0.002/ -0.000	
-158	4.750	4.937	xxxxFHx09304750195xxx
-159	5.000	5.187	xxxxFHx09305000195xxx
-160	5.250	5.437	xxxxFHx09305250195xxx
-161	5.500	5.687	xxxxFHx09305500195xxx
-162	5.750	5.928	xxxxFHx09305750195xxx
-163	6.000	6.187	xxxxFHx09306000195xxx

R = 0.010" max. radius

G for FH Seal groove = 0.285/0.295" (265 callout)

	+0.000/ -0.002	+0.002/ -0.000	
-202	0.250	0.500	xxxxFHx12500250265xxx
-203	0.312	0.562	xxxxFHx12500312265xxx
-204	0.375	0.625	xxxxFHx12500375265xxx
-205	0.437	0.687	xxxxFHx12500437265xxx
-206	0.500	0.750	xxxxFHx12500500265xxx
-207	0.562	0.812	xxxxFHx12500562265xxx
-208	0.625	0.875	xxxxFHx12500625265xxx
-209	0.687	0.937	xxxxFHx12500687265xxx
-210	0.750	1.000	xxxxFHx12500750265xxx
-211	0.812	1.062	xxxxFHx12500812265xxx
-212	0.875	1.125	xxxxFHx12500875265xxx
-213	0.937	1.187	xxxxFHx12500937265xxx
-214	1.000	1.250	xxxxFHx12501000265xxx
-215	1.062	1.312	xxxxFHx12501062265xxx
-216	1.125	1.375	xxxxFHx12501125265xxx
-217	1.187	1.437	xxxxFHx12501187265xxx
-218	1.250	1.500	xxxxFHx12501250265xxx
-219	1.312	1.562	xxxxFHx12501312265xxx
-220	1.375	1.625	xxxxFHx12501375265xxx
-221	1.437	1.687	xxxxFHx12501437265xxx
-222	1.500	1.750	xxxxFHx12501500265xxx
-223	1.625	1.875	xxxxFHx12501625265xxx
-224	1.750	2.000	xxxxFHx12501750265xxx

Dash #	A Shaft Diameter	B Groove Diameter	Part Number
-225	1.875	2.125	xxxxFHx12501875265xxx
-226	2.000	2.250	xxxxFHx12502000265xxx
-227	2.125	2.375	xxxxFHx12502125265xxx
-228	2.250	2.500	xxxxFHx12502250265xxx
-229	2.375	2.625	xxxxFHx12502375265xxx
-230	2.500	2.750	xxxxFHx12502500265xxx
-231	2.625	2.875	xxxxFHx12502625265xxx
-232	2.750	3.000	xxxxFHx12502750265xxx
-233	2.875	3.125	xxxxFHx12502875265xxx
-234	3.000	3.250	xxxxFHx12503000265xxx
-235	3.125	3.375	xxxxFHx12503125265xxx
-236	3.250	3.500	xxxxFHx12503250265xxx
-237	3.375	3.625	xxxxFHx12503375265xxx
-238	3.500	3.750	xxxxFHx12503500265xxx
-239	3.625	3.875	xxxxFHx12503625265xxx
-240	3.750	4.000	xxxxFHx12503750265xxx
-241	3.875	4.125	xxxxFHx12503875265xxx
-242	4.000	4.250	xxxxFHx12504000265xxx
-243	4.125	4.375	xxxxFHx12504125265xxx
-244	4.250	4.500	xxxxFHx12504250265xxx
-245	4.375	4.625	xxxxFHx12504375265xxx
-246	4.500	4.750	xxxxFHx12504500265xxx
-247	4.625	4.875	xxxxFHx12504625265xxx
-248	4.750	5.000	xxxxFHx12504750265xxx
-249	4.875	5.125	xxxxFHx12504875265xxx
-250	5.000	5.250	xxxxFHx12505000265xxx
-251	5.125	5.375	xxxxFHx12505125265xxx
-252	5.250	5.500	xxxxFHx12505250265xxx
-253	5.375	5.625	xxxxFHx12505375265xxx
-254	5.500	5.750	xxxxFHx12505500265xxx
-255	5.625	5.875	xxxxFHx12505625265xxx
-256	5.750	6.000	xxxxFHx12505750265xxx
-257	5.875	6.125	xxxxFHx12505875265xxx
-258	6.000	6.250	xxxxFHx12506000265xxx
-259	6.250	6.500	xxxxFHx12506250265xxx

02/15/08



Table 7-7. FC and FH Inch/Fractional Gland Dimensions (Continued)

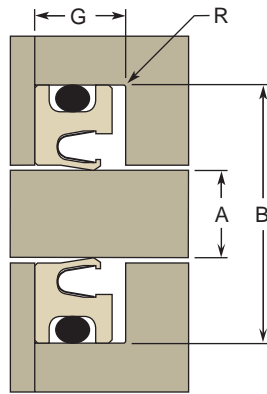

Rotary Seal

Dash #	A Shaft Diameter	B Groove Diameter	Part Number
--------	------------------	-------------------	-------------

R = 0.010" max. radius

G for FH Seal groove = 0.285/0.295" (265 callout)

	+0.000/ -0.002	+0.002/ -0.000	
-260	6.500	6.750	xxxxFHx12506500265xxx
-261	6.750	7.000	xxxxFHx12506750265xxx
-262	7.000	7.250	xxxxFHx12507000265xxx
-263	7.250	7.500	xxxxFHx12507250265xxx
-264	7.500	7.750	xxxxFHx12507500265xxx
-265	7.750	8.000	xxxxFHx12507750265xxx
-266	8.000	8.250	xxxxFHx12508000265xxx
-267	8.250	8.500	xxxxFHx12508250265xxx
-268	8.500	8.750	xxxxFHx12508500265xxx
-269	8.750	9.000	xxxxFHx12508750265xxx
-270	9.000	9.250	xxxxFHx12509000265xxx
-271	9.250	9.500	xxxxFHx12509250265xxx
-272	9.500	9.750	xxxxFHx12509500265xxx
-273	9.750	10.000	xxxxFHx12509750265xxx
-274	10.000	10.250	xxxxFHx12510000265xxx
-275	10.500	10.750	xxxxFHx12510500265xxx
-276	11.000	11.250	xxxxFHx12511000265xxx
-277	11.500	11.750	xxxxFHx12511500265xxx
-278	12.000	12.250	xxxxFHx12512000265xxx
-279	12.500	12.750	xxxxFHx12512500265xxx
-280	13.000	13.250	xxxxFHx12513000265xxx
-281	13.500	13.750	xxxxFHx12513500265xxx

R = 0.015" max. radius

G for FC Seal groove = 0.281/0.291" (260 callout)
 G for FH Seal groove = 0.370/0.380" (345 callout)

	+0.000/ -0.002	+0.002/ -0.000	
-310	0.500	0.875	xxxxFCx18700500260xxx
-311	0.562	0.937	xxxxFCx18700562260xxx
-312	0.625	1.000	xxxxFCx18700625260xxx
-313	0.687	1.062	xxxxFCx18700687260xxx
-314	0.750	1.125	xxxxFCx18700750260xxx
-315	0.812	1.187	xxxxFCx18700812260xxx

Dash #	A Shaft Diameter	B Groove Diameter	Part Number
-316	0.875	1.250	xxxxFCx18700875260xxx
-317	0.937	1.312	xxxxFCx18700937260xxx
-318	1.000	1.375	xxxxFCx18701000260xxx
-319	1.062	1.437	xxxxFCx18701062260xxx
-320	1.125	1.500	xxxxFCx18701125260xxx
-321	1.187	1.562	xxxxFCx18701187260xxx
-322	1.250	1.625	xxxxFCx18701250260xxx
-323	1.312	1.687	xxxxFCx18701312260xxx
-324	1.375	1.750	xxxxFCx18701375260xxx
-325	1.500	1.875	xxxxFCx18701500260xxx
-326	1.625	2.000	xxxxFCx18701625260xxx
-327	1.750	2.125	xxxxFCx18701750260xxx
-328	1.875	2.250	xxxxFCx18701875260xxx
-329	2.000	2.375	xxxxFCx18702000260xxx
-330	2.125	2.500	xxxxFCx18702125260xxx
-331	2.250	2.625	xxxxFCx18702250260xxx
-332	2.375	2.750	xxxxFCx18702375260xxx
-333	2.500	2.875	xxxxFCx18702500260xxx
-334	2.625	3.000	xxxxFCx18702625260xxx
-335	2.750	3.125	xxxxFCx18702750260xxx
-336	2.875	3.250	xxxxFCx18702875260xxx
-337	3.000	3.375	xxxxFCx18703000260xxx
-338	3.125	3.500	xxxxFCx18703125260xxx
-339	3.250	3.625	xxxxFCx18703250260xxx
-340	3.375	3.750	xxxxFCx18703375260xxx
-341	3.500	3.875	xxxxFCx18703500260xxx
-342	3.625	4.000	xxxxFCx18703625260xxx
-343	3.750	4.125	xxxxFCx18703750260xxx
-344	3.875	4.250	xxxxFCx18703875260xxx
-345	4.000	4.375	xxxxFCx18704000260xxx
-346	4.125	4.500	xxxxFCx18704125260xxx
-347	4.250	4.625	xxxxFCx18704250260xxx
-348	4.375	4.750	xxxxFCx18704375260xxx
-349	4.500	4.875	xxxxFCx18704500260xxx
-350	4.625	5.000	xxxxFCx18704625260xxx
-351	4.750	5.125	xxxxFCx18704750260xxx



02/15/08



Table 7-7. FC and FH Inch/Fractional Gland Dimensions (Continued)

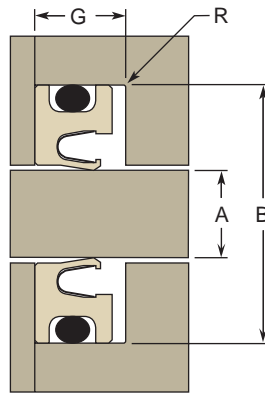

Rotary Seal

Dash #	A Shaft Diameter	B Groove Diameter	Part Number
--------	------------------	-------------------	-------------

R = 0.015" max. radius

G for FC Seal groove = 0.281/0.291" (260 callout)

G for FH Seal groove = 0.370/0.380" (345 callout)

	+0.00/ -0.002	+0.002/ -0.000	
-352	4.875	5.250	xxxxFCx18704875260xxx
-353	5.000	5.375	xxxxFCx18705000260xxx
-354	5.125	5.500	xxxxFCx18705125260xxx
-355	5.250	5.625	xxxxFCx18705250260xxx
-356	5.375	5.750	xxxxFCx18705375260xxx
-357	5.500	5.875	xxxxFCx18705500260xxx
-358	5.625	6.000	xxxxFCx18705625260xxx
-359	5.750	6.125	xxxxFCx18705750260xxx
-360	5.875	6.250	xxxxFCx18705875260xxx
-361	6.000	6.375	xxxxFCx18706000260xxx
-362	6.250	6.625	xxxxFCx18706250260xxx
-363	6.500	6.875	xxxxFCx18706500260xxx
-364	6.750	7.125	xxxxFCx18706750260xxx
-365	7.000	7.375	xxxxFCx18707000260xxx
-366	7.250	7.625	xxxxFCx18707250260xxx
-367	7.500	7.875	xxxxFCx18707500260xxx
-368	7.750	8.125	xxxxFCx18707750260xxx
-369	8.000	8.375	xxxxFCx18708000260xxx
-370	8.250	8.625	xxxxFCx18708250260xxx
-371	8.500	8.875	xxxxFCx18708500260xxx
-372	8.750	9.125	xxxxFCx18708750260xxx
-373	9.000	9.375	xxxxFCx18709000260xxx
-374	9.250	9.625	xxxxFCx18709250260xxx
-375	9.500	9.875	xxxxFCx18709500260xxx
-376	9.750	10.125	xxxxFCx18709750260xxx
-377	10.000	10.375	xxxxFCx18710000260xxx
-378	10.500	10.875	xxxxFCx18710500260xxx
-379	11.000	11.375	xxxxFCx18711000260xxx
-380	11.500	11.875	xxxxFCx18711500260xxx
-381	12.000	12.375	xxxxFCx18712000260xxx
-382	13.000	13.375	xxxxFCx18713000260xxx
-383	14.000	14.375	xxxxFCx18714000260xxx

Dash #	A Shaft Diameter	B Groove Diameter	Part Number
-384	15.000	15.375	xxxxFCx18715000260xxx
-385	16.000	16.375	xxxxFCx18716000260xxx
-386	17.000	17.375	xxxxFCx18717000260xxx
-387	18.000	18.375	xxxxFCx18718000260xxx
-388	19.000	19.375	xxxxFCx18719000260xxx
-389	20.000	20.375	xxxxFCx18720000260xxx
-390	21.000	21.375	xxxxFCx18721000260xxx
-391	22.000	22.375	xxxxFCx18722000260xxx
-392	23.000	23.375	xxxxFCx18723000260xxx
-393	24.000	24.375	xxxxFCx18724000260xxx
-394	25.000	25.375	xxxxFCx18725000260xxx
-395	26.000	26.375	xxxxFCx18726000260xxx

R = 0.015" max. radius

G for FC Seal groove = 0.375/0.385" (355 callout)

G for FH Seal groove = 0.450/0.460" (425 callout)

	+0.00/ -0.003	+0.003/ -0.000	
-401	1.500	2.000	xxxxFCx25001500355xxx
-402	1.625	2.125	xxxxFCx25001625355xxx
-403	1.750	2.250	xxxxFCx25001750355xxx
-404	1.875	2.375	xxxxFCx25001875355xxx
-405	2.000	2.500	xxxxFCx25002000355xxx
-406	2.125	2.625	xxxxFCx25002125355xxx
-407	2.250	2.750	xxxxFCx25002250355xxx
-408	2.375	2.875	xxxxFCx25002375355xxx
-409	2.500	3.000	xxxxFCx25002500355xxx
-410	2.625	3.125	xxxxFCx25002625355xxx
-411	2.750	3.250	xxxxFCx25002750355xxx
-412	2.875	3.375	xxxxFCx25002875355xxx
-413	3.000	3.500	xxxxFCx25003000355xxx
-414	3.125	3.625	xxxxFCx25003125355xxx
-415	3.250	3.750	xxxxFCx25003250355xxx
-416	3.375	3.875	xxxxFCx25003375355xxx
-417	3.500	4.000	xxxxFCx25003500355xxx
-418	3.625	4.125	xxxxFCx25003625355xxx

02/15/08



Table 7-7. FC and FH Inch/Fractional Gland Dimensions (Continued)

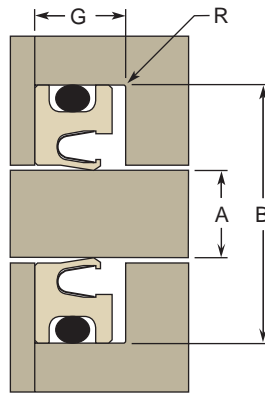

Rotary Seal

Dash #	A Shaft Diameter	B Groove Diameter	Part Number
--------	------------------	-------------------	-------------

R = 0.015" max. radius

G for FC Seal groove = 0.375/0.385" (355 callout)

G for FH Seal groove = 0.450/0.46" (425 callout)

	+0.000/ -0.003	+0.003/ -0.000	
-419	3.750	4.250	xxxxFCx25003750355xxx
-420	3.875	4.375	xxxxFCx25003875355xxx
-421	4.000	4.500	xxxxFCx25004000355xxx
-422	4.125	4.625	xxxxFCx25004125355xxx
-423	4.250	4.750	xxxxFCx25004250355xxx
-424	4.375	4.875	xxxxFCx25004375355xxx
-425	4.500	5.000	xxxxFCx25004500355xxx
-426	4.625	5.125	xxxxFCx25004625355xxx
-427	4.750	5.250	xxxxFCx25004750355xxx
-428	4.875	5.375	xxxxFCx25004875355xxx
-429	5.000	5.500	xxxxFCx25005000355xxx
-430	5.125	5.625	xxxxFCx25005125355xxx
-431	5.250	5.750	xxxxFCx25005250355xxx
-432	5.375	5.875	xxxxFCx25005375355xxx
-433	5.500	6.000	xxxxFCx25005500355xxx
-434	5.625	6.125	xxxxFCx25005625355xxx
-435	5.750	6.250	xxxxFCx25005750355xxx
-436	5.875	6.375	xxxxFCx25005875355xxx
-437	6.000	6.500	xxxxFCx25006000355xxx
-438	6.250	6.750	xxxxFCx25006250355xxx
-439	6.500	7.000	xxxxFCx25006500355xxx
-440	6.750	7.250	xxxxFCx25006750355xxx
-441	7.000	7.500	xxxxFCx25007000355xxx
-442	7.250	7.750	xxxxFCx25007250355xxx
-443	7.500	8.000	xxxxFCx25007500355xxx
-444	7.750	8.250	xxxxFCx25007750355xxx

Dash #	A Shaft Diameter	B Groove Diameter	Part Number
-445	8.000	8.500	xxxxFCx25008000355xxx
-446	8.500	9.000	xxxxFCx25008500355xxx
-447	9.000	9.500	xxxxFCx25009000355xxx
-448	9.500	10.000	xxxxFCx25009500355xxx
-449	10.000	10.500	xxxxFCx25010000355xxx
-450	10.500	11.000	xxxxFCx25010500355xxx
-451	11.000	11.500	xxxxFCx25011000355xxx
-452	11.500	12.000	xxxxFCx25011500355xxx
-453	12.000	12.500	xxxxFCx25012000355xxx
-454	12.500	13.000	xxxxFCx25012500355xxx
-455	13.000	13.500	xxxxFCx25013000355xxx
-456	13.500	14.000	xxxxFCx25013500355xxx
-457	14.000	14.500	xxxxFCx25014000355xxx
-458	14.500	15.000	xxxxFCx25014500355xxx
-459	15.000	15.500	xxxxFCx25015000355xxx
-460	15.500	16.000	xxxxFCx25015500355xxx
-461	16.000	16.500	xxxxFCx25016000355xxx
-462	16.500	17.000	xxxxFCx25016500355xxx
-463	17.000	17.500	xxxxFCx25017000355xxx
-464	17.500	18.000	xxxxFCx25017500355xxx
-465	18.000	18.500	xxxxFCx25018000355xxx
-466	18.500	19.000	xxxxFCx25018500355xxx
-467	19.000	19.500	xxxxFCx25019000355xxx
-468	19.500	20.000	xxxxFCx25019500355xxx
-469	20.000	20.500	xxxxFCx25020000355xxx
-470	21.000	21.500	xxxxFCx25021000355xxx
-471	22.000	22.500	xxxxFCx25022000355xxx
-472	23.000	23.500	xxxxFCx25023000355xxx
-473	24.000	24.500	xxxxFCx25024000355xxx
-474	25.000	25.500	xxxxFCx25025000355xxx
-475	26.000	26.500	xxxxFCx25026000355xxx



02/15/08



FlexiSeal® Rotary Seals

FC and FH Profiles — Metric

Catalog EPS 5340/USA

Metric FC and FH Profiles

FC FlexiSeal Rotary Shaft, Centered O-Ring profiles and FH FlexiSeal Rotary Shaft, O-Ring in Heel profiles are available in Metric sizes on the following page.

Design Considerations

- Hardware Configurations/Installation, see **Page 2-3**
- Surface Finish and Hardness, see **Page 2-9**
- Extrusion Gaps and High Pressure, see **Page 2-10**
- Spring Choices, see **Page 2-12**
- Lip Shapes, see **Page 2-16**
- Rotary Seal Considerations, see **Page 2-17**
- Shaft Misalignment Issues, see **Page 2-19**

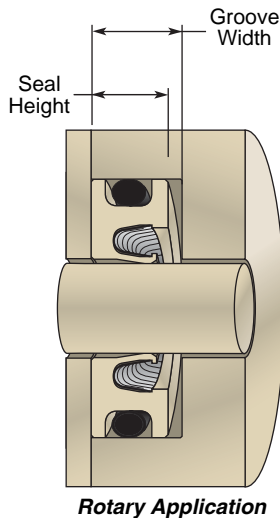

Table 7-8. Seal Height Callouts

Radial Cross-Section	Std. FC Seal Height Callout	Std. FH Seal Height Callout
0250	N/A	050
0400	N/A	067
0500	066	088
0700	090	108

Note: FH profiles are available in extended heel only.

Part Number Example

Table 7-9. FC and FH Metric Part Number

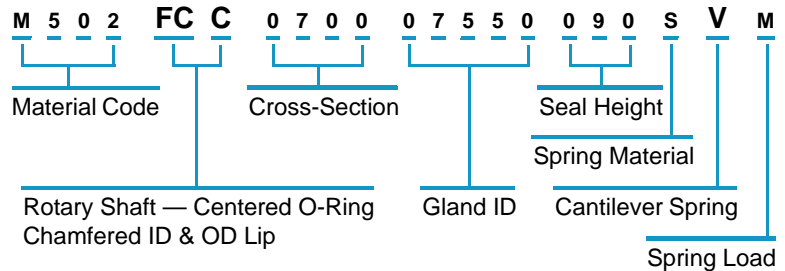

Extended Heel Option

All part numbers on the following page call for the standard seal height for pressures below 3000 psi.

The heel of a FlexiSeal can be extended to increase extrusion resistance simply by changing the seal height callout in the part number.

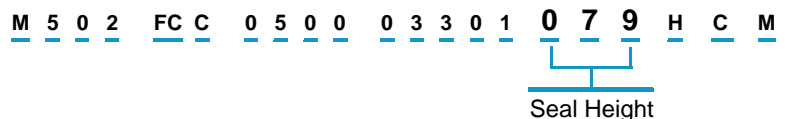
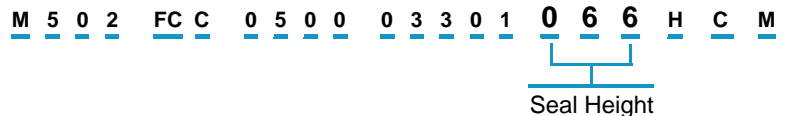

01/15/07



Gland Dimensions — Metric FC & FH Profiles

Table 7-10. FC and FH Metric Gland Dimensions

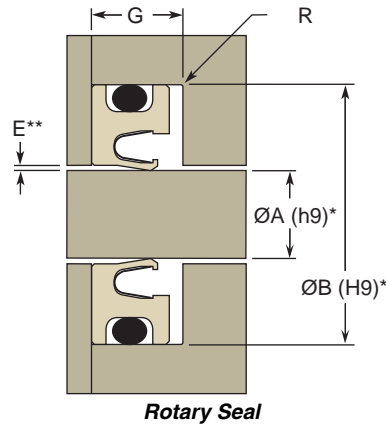

Each of these FlexiSeal profiles were designed to fit into the Metric glands on this page.

FC part numbers are available only in 0400 (4 mm) cross-section and higher.

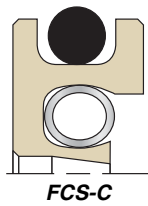
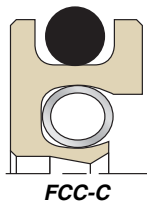
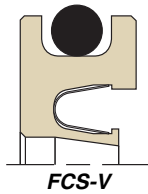
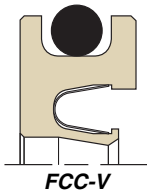

FH part numbers are available in extended heel only.

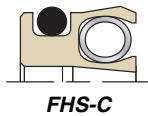
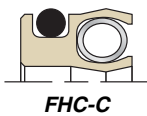
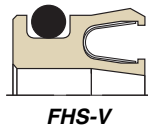
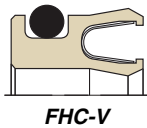

Cross-Section Callout	Gland Cross-Section	FC Seal Height Callout	FH Seal Height Callout	FC Groove Width (G) +0.25/-0.00 mm	FH Groove Width (G) +0.25/-0.00 mm	Max Radius (R)
0250	2.50 mm	N/A	050	N/A	5.33 mm	0.25 mm
0400	4.00 mm	N/A	067	N/A	7.24 mm	0.25 mm
0500	5.00 mm	066	088	7.14 mm	9.40 mm	0.38 mm
0700	7.00 mm	090	108	9.53 mm	11.43 mm	0.38 mm

* For ISO Tolerances see **Appendix D**.

** See **Page 2-10** for more on extrusion gap.

Example Part Numbers

Part Number	Shaft Ø (A) in mm	Groove fl (B) in mm	Groove Width (G) in mm
FCS-V Profile			
M301FCS070006504090EVM	65.04 + .00/-0.07	79.04 + .07/-0.00	9.53 + 0.25/-0.00
FHC-C Profile			
M602FHC040002900067SCL	29.00+ 00/-0.052	37.00 .062/-0.00	7.24 + 0.25/-0.00



02/15/08



FlexiSeal® Rotary Seals

FF Profiles — Flanged Inch/Fractional

Catalog EPS 5340/USA



Flanged FlexiSeals

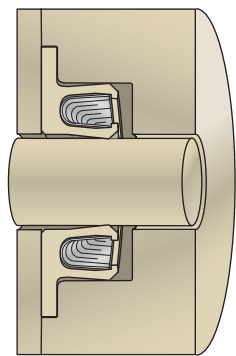

Flanged Rotary Application

FF Profiles

FF FlexiSeal Rotary Shaft, Flanged profiles are clamped axially in the gland to ensure that the seal does not spin with the shaft, especially in applications with frequent thermal cycling.

Design Considerations

- Hardware Configurations/Installation, see **Page 2-3**
- Surface Finish and Hardness, see **Page 2-9**
- Extrusion Gaps and High Pressure, see **Page 2-10**
- Spring Choices, see **Page 2-12**
- Lip Shapes, see **Page 2-16**
- Rotary Seal Considerations, see **Page 2-17**
- Shaft Misalignment Issues, see **Page 2-19**

Part Number Example

Table 7-11. FF Flanged Inch/Fractional Part Number

<u>0</u>	<u>5</u>	<u>0</u>	<u>2</u>	<u>FF</u>	<u>C</u>	<u>1</u>	<u>2</u>	<u>5</u>	<u>0</u>	<u>1</u>	<u>2</u>	<u>5</u>	<u>0</u>	<u>1</u>	<u>7</u>	<u>0</u>	<u>S</u>	<u>V</u>	<u>M</u>
				└─┬─┘										└─┬─┘					
				Rotary Shaft — Flanged										Cantilever Spring					
				Chamfered ID & OD Lip															

Gland Dimensions — FF Profiles, Flanged

Table 7-12. FF Flanged Inch/Fractional Gland Dimensions

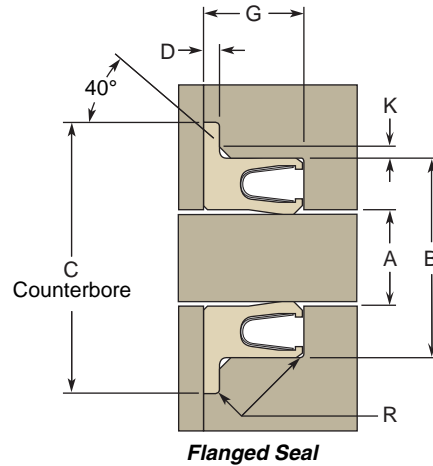

Each of these FlexiSeal profiles were designed to fit into either the Inch/Fractional glands on the following pages or the Metric glands on **Page 7-26**.

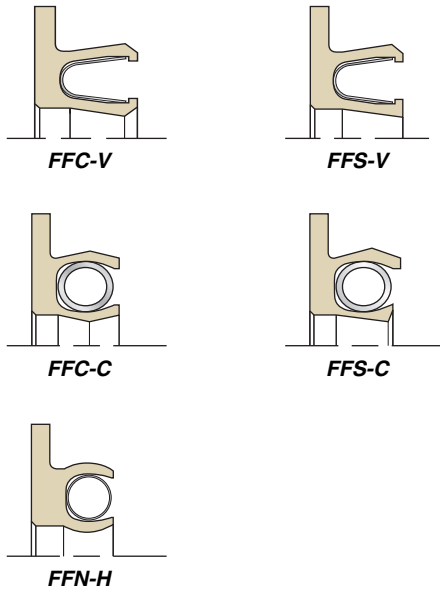

Dash #	A Shaft Dia.	B Groove Dia.	C Flange C-Bore Dia. Min.	Part Number
--------	--------------	---------------	---------------------------	-------------

R = 0.007" max. radius
 K = 0.017" Ref.
 G for Standard heel groove = 0.094/0.104" (083 callout)
 D Gland Counterbore depth for seal flange = 0.011/0.013"

	+0.000/ -0.002	+0.002/ -0.000		
-006	0.125	0.250	0.400	xxxxFFx06200125083xxx
-007	0.156	0.281	0.431	xxxxFFx06200156083xxx
-008	0.187	0.312	0.462	xxxxFFx06200187083xxx
-009	0.218	0.343	0.493	xxxxFFx06200218083xxx
-010	0.250	0.375	0.525	xxxxFFx06200250083xxx
-011	0.312	0.437	0.587	xxxxFFx06200312083xxx
-012	0.375	0.500	0.650	xxxxFFx06200375083xxx
-013	0.437	0.562	0.712	xxxxFFx06200437083xxx
-014	0.500	0.625	0.775	xxxxFFx06200500083xxx
-015	0.562	0.687	0.837	xxxxFFx06200562083xxx
-016	0.625	0.750	0.900	xxxxFFx06200625083xxx
-017	0.687	0.812	0.962	xxxxFFx06200687083xxx
-018	0.750	0.875	1.025	xxxxFFx06200750083xxx
-019	0.812	0.937	1.087	xxxxFFx06200812083xxx
-020	0.875	1.000	1.150	xxxxFFx06200875083xxx
-021	0.937	1.062	1.212	xxxxFFx06200937083xxx
-022	1.000	1.125	1.275	xxxxFFx06201000083xxx
-023	1.062	1.187	1.337	xxxxFFx06201062083xxx
-024	1.125	1.250	1.400	xxxxFFx06201125083xxx
-025	1.187	1.312	1.462	xxxxFFx06201187083xxx
-026	1.250	1.375	1.525	xxxxFFx06201250083xxx
-027	1.312	1.437	1.587	xxxxFFx06201312083xxx
-028	1.375	1.500	1.650	xxxxFFx06201375083xxx
-029	1.500	1.625	1.775	xxxxFFx06201500083xxx
-030	1.625	1.750	1.900	xxxxFFx06201625083xxx
-031	1.750	1.875	2.025	xxxxFFx06201750083xxx



02/15/08



Table 7-12. FF Flanged Inch/Fractional Gland Dimensions (Continued)

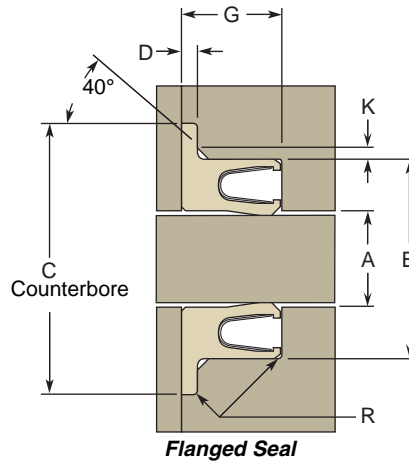

Dash #	A Shaft Dia.	B Groove Dia.	C Flange C-Bore Dia. Min.	Part Number
--------	--------------	---------------	---------------------------	-------------

R = 0.007" max. radius
 K = 0.017" Ref.
 G for Standard heel groove = 0.094/0.104" (083 callout)
 D Gland Counterbore depth for seal flange = 0.011/0.013"

	+0.00/ -0.02	+0.002/ -0.000		
-032	1.875	2.000	2.150	xxxxFFx06201875083xxx
-033	2.000	2.125	2.275	xxxxFFx06202000083xxx
-034	2.125	2.250	2.400	xxxxFFx06202125083xxx
-035	2.250	2.375	2.525	xxxxFFx06202250083xxx
-036	2.375	2.500	2.650	xxxxFFx06202375083xxx
-037	2.500	2.625	2.775	xxxxFFx06202500083xxx
-038	2.625	2.750	2.900	xxxxFFx06202625083xxx
-039	2.750	2.875	3.025	xxxxFFx06202750083xxx
-040	2.875	3.000	3.150	xxxxFFx06202875083xxx
-041	3.000	3.125	3.275	xxxxFFx06203000083xxx
-042	3.250	3.375	3.525	xxxxFFx06203250083xxx
-043	3.500	3.625	3.775	xxxxFFx06203500083xxx
-044	3.750	3.875	4.025	xxxxFFx06203750083xxx
-045	4.000	4.125	4.275	xxxxFFx06204000083xxx

R = 0.010" max. radius
 K = 0.028" Ref.
 G for Standard heel groove = 0.141/0.151" (130 callout)
 D Gland Counterbore depth for seal flange = 0.017/0.020"

	+0.00/ -0.02	+0.002/ -0.000		
-106	0.187	0.375	0.530	xxxxFFx09300187130xxx
-107	0.219	0.406	0.561	xxxxFFx09300219130xxx
-108	0.250	0.437	0.592	xxxxFFx09300250130xxx
-109	0.312	0.500	0.655	xxxxFFx09300312130xxx
-110	0.375	0.562	0.717	xxxxFFx09300375130xxx
-111	0.437	0.625	0.780	xxxxFFx09300437130xxx
-112	0.500	0.687	0.842	xxxxFFx09300500130xxx
-113	0.562	0.750	0.905	xxxxFFx09300562130xxx
-114	0.625	0.812	0.967	xxxxFFx09300625130xxx
-115	0.687	0.875	1.030	xxxxFFx09300687130xxx
-116	0.750	0.937	1.092	xxxxFFx09300750130xxx
-117	0.812	1.000	1.155	xxxxFFx09300812130xxx

Dash #	A Shaft Dia.	B Groove Dia.	C Flange C-Bore Dia. Min.	Part Number
--------	--------------	---------------	---------------------------	-------------

-118	0.875	1.062	1.217	xxxxFFx09300875130xxx
-119	0.937	1.125	1.280	xxxxFFx09300937130xxx
-120	1.000	1.187	1.342	xxxxFFx09301000130xxx
-121	1.062	1.250	1.405	xxxxFFx09301062130xxx
-122	1.125	1.312	1.467	xxxxFFx09301125130xxx
-123	1.187	1.375	1.530	xxxxFFx09301187130xxx
-124	1.250	1.437	1.592	xxxxFFx09301250130xxx
-125	1.312	1.500	1.655	xxxxFFx09301312130xxx
-126	1.375	1.562	1.717	xxxxFFx09301375130xxx
-127	1.437	1.625	1.780	xxxxFFx09301437130xxx
-128	1.500	1.687	1.842	xxxxFFx09301500130xxx
-129	1.562	1.750	1.905	xxxxFFx09301562130xxx
-130	1.625	1.812	1.967	xxxxFFx09301625130xxx
-131	1.687	1.875	2.030	xxxxFFx09301687130xxx
-132	1.750	1.937	2.092	xxxxFFx09301750130xxx
-133	1.812	2.000	2.155	xxxxFFx09301812130xxx
-134	1.875	2.062	2.217	xxxxFFx09301875130xxx
-135	1.937	2.125	2.280	xxxxFFx09301937130xxx
-136	2.000	2.187	2.342	xxxxFFx09302000130xxx
-137	2.062	2.250	2.405	xxxxFFx09302062130xxx
-138	2.125	2.312	2.467	xxxxFFx09302125130xxx
-139	2.187	2.375	2.530	xxxxFFx09302187130xxx
-140	2.250	2.437	2.592	xxxxFFx09302250130xxx
-141	2.312	2.500	2.655	xxxxFFx09302312130xxx
-142	2.375	2.562	2.717	xxxxFFx09302375130xxx
-143	2.437	2.625	2.780	xxxxFFx09302437130xxx
-144	2.500	2.687	2.842	xxxxFFx09302500130xxx
-145	2.562	2.750	2.905	xxxxFFx09302562130xxx
-146	2.625	2.812	2.967	xxxxFFx09302625130xxx
-147	2.687	2.875	3.030	xxxxFFx09302687130xxx
-148	2.750	2.937	3.092	xxxxFFx09302750130xxx
-149	2.812	3.000	3.155	xxxxFFx09302812130xxx
-150	2.875	3.062	3.217	xxxxFFx09302875130xxx
-151	3.000	3.187	3.342	xxxxFFx09303000130xxx

02/15/08



Table 7-12. FF Flanged Inch/Fractional Gland Dimensions (Continued)

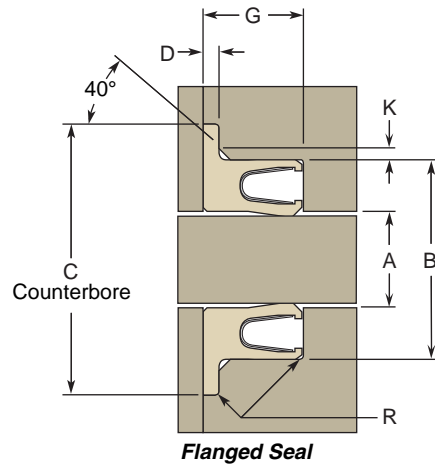

Dash #	A Shaft Dia.	B Groove Dia.	C Flange C-Bore Dia. Min.	Part Number
--------	--------------	---------------	---------------------------	-------------

R = 0.010" max. radius
K = 0.028" Ref.
G for Standard heel groove = 0.141/0.151" (130 callout)
D Gland Counterbore depth for seal flange = 0.017/0.020"

	+0.000/ -0.002	+0.002/ -0.000		
-152	3.250	3.437	3.592	xxxxFFx09303250130xxx
-153	3.500	3.687	3.842	xxxxFFx09303500130xxx
-154	3.750	3.937	4.092	xxxxFFx09303750130xxx
-155	4.000	4.187	4.342	xxxxFFx09304000130xxx
-156	4.250	4.437	4.592	xxxxFFx09304250130xxx
-157	4.500	4.687	4.842	xxxxFFx09304500130xxx
-158	4.750	4.937	5.092	xxxxFFx09304750130xxx
-159	5.000	5.187	5.342	xxxxFFx09305000130xxx
-160	5.250	5.437	5.592	xxxxFFx09305250130xxx
-161	5.500	5.687	5.842	xxxxFFx09305500130xxx
-162	5.750	5.928	6.083	xxxxFFx09305750130xxx
-163	6.000	6.187	6.342	xxxxFFx09306000130xxx

R = 0.010" max. radius
K = 0.040" Ref.
G for Standard heel groove = 0.188/0.198" (170 callout)
D Gland Counterbore depth for seal flange = 0.024/0.027"

	+0.000/ -0.002	+0.002/ -0.000		
-202	0.250	0.500	0.687	xxxxFFx12500250170xxx
-203	0.312	0.562	0.749	xxxxFFx12500312170xxx
-204	0.375	0.625	0.812	xxxxFFx12500375170xxx
-205	0.437	0.687	0.874	xxxxFFx12500437170xxx
-206	0.500	0.750	0.937	xxxxFFx12500500170xxx
-207	0.562	0.812	0.999	xxxxFFx12500562170xxx
-208	0.625	0.875	1.062	xxxxFFx12500625170xxx
-209	0.687	0.937	1.124	xxxxFFx12500687170xxx
-210	0.750	1.000	1.187	xxxxFFx12500750170xxx
-211	0.812	1.062	1.249	xxxxFFx12500812170xxx
-212	0.875	1.125	1.312	xxxxFFx12500875170xxx
-213	0.937	1.187	1.374	xxxxFFx12500937170xxx

Dash #	A Shaft Dia.	B Groove Dia.	C Flange C-Bore Dia. Min.	Part Number
--------	--------------	---------------	---------------------------	-------------

-214	1.000	1.250	1.437	xxxxFFx12501000170xxx
-215	1.062	1.312	1.499	xxxxFFx12501062170xxx
-216	1.125	1.375	1.562	xxxxFFx12501125170xxx
-217	1.187	1.437	1.624	xxxxFFx12501187170xxx
-218	1.250	1.500	1.687	xxxxFFx12501250170xxx
-219	1.312	1.562	1.749	xxxxFFx12501312170xxx
-220	1.375	1.625	1.812	xxxxFFx12501375170xxx
-221	1.437	1.687	1.874	xxxxFFx12501437170xxx
-222	1.500	1.750	1.937	xxxxFFx12501500170xxx
-223	1.625	1.875	2.062	xxxxFFx12501625170xxx
-224	1.750	2.000	2.187	xxxxFFx12501750170xxx
-225	1.875	2.125	2.312	xxxxFFx12501875170xxx
-226	2.000	2.250	2.437	xxxxFFx12502000170xxx
-227	2.125	2.375	2.562	xxxxFFx12502125170xxx
-228	2.250	2.500	2.687	xxxxFFx12502250170xxx
-229	2.375	2.625	2.812	xxxxFFx12502375170xxx
-230	2.500	2.750	2.937	xxxxFFx12502500170xxx
-231	2.625	2.875	3.062	xxxxFFx12502625170xxx
-232	2.750	3.000	3.187	xxxxFFx12502750170xxx
-233	2.875	3.125	3.312	xxxxFFx12502875170xxx
-234	3.000	3.250	3.437	xxxxFFx12503000170xxx
-235	3.125	3.375	3.562	xxxxFFx12503125170xxx
-236	3.250	3.500	3.687	xxxxFFx12503250170xxx
-237	3.375	3.625	3.812	xxxxFFx12503375170xxx
-238	3.500	3.750	3.937	xxxxFFx12503500170xxx
-239	3.625	3.875	4.062	xxxxFFx12503625170xxx
-240	3.750	4.000	4.187	xxxxFFx12503750170xxx
-241	3.875	4.125	4.312	xxxxFFx12503875170xxx
-242	4.000	4.250	4.437	xxxxFFx12504000170xxx
-243	4.125	4.375	4.562	xxxxFFx12504125170xxx
-244	4.250	4.500	4.687	xxxxFFx12504250170xxx
-245	4.375	4.625	4.812	xxxxFFx12504375170xxx



02/15/08



Table 7-12. FF Flanged Inch/Fractional Gland Dimensions (Continued)

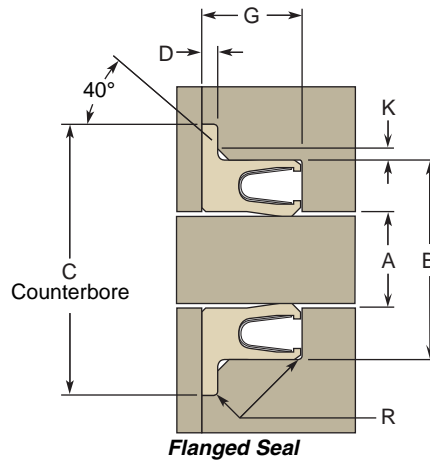

Dash #	A Shaft Dia.	B Groove Dia.	C Flange C-Bore Dia. Min.	Part Number
--------	--------------	---------------	---------------------------	-------------

R = 0.010" max. radius
 K = 0.040" Ref.
 G for Standard heel groove = 0.188/0.198" (170 callout)
 D Gland Counterbore depth for seal flange = 0.024/0.027"

	+0.00/-0.002	+0.002/-0.000		
-246	4.500	4.750	4.937	xxxxFFx12504500170xxx
-247	4.625	4.875	5.062	xxxxFFx12504625170xxx
-248	4.750	5.000	5.187	xxxxFFx12504750170xxx
-249	4.875	5.125	5.312	xxxxFFx12504875170xxx
-250	5.000	5.250	5.437	xxxxFFx12505000170xxx
-251	5.125	5.375	5.562	xxxxFFx12505125170xxx
-252	5.250	5.500	5.687	xxxxFFx12505250170xxx
-253	5.375	5.625	5.812	xxxxFFx12505375170xxx
-254	5.500	5.750	5.937	xxxxFFx12505500170xxx
-255	5.625	5.875	6.062	xxxxFFx12505625170xxx
-256	5.750	6.000	6.187	xxxxFFx12505750170xxx
-257	5.875	6.125	6.312	xxxxFFx12505875170xxx
-258	6.000	6.250	6.437	xxxxFFx12506000170xxx
-259	6.250	6.500	6.687	xxxxFFx12506250170xxx
-260	6.500	6.750	6.937	xxxxFFx12506500170xxx
-261	6.750	7.000	7.187	xxxxFFx12506750170xxx
-262	7.000	7.250	7.437	xxxxFFx12507000170xxx
-263	7.250	7.500	7.687	xxxxFFx12507250170xxx
-264	7.500	7.750	7.937	xxxxFFx12507500170xxx
-265	7.750	8.000	8.187	xxxxFFx12507750170xxx
-266	8.000	8.250	8.437	xxxxFFx12508000170xxx
-267	8.250	8.500	8.687	xxxxFFx12508250170xxx
-268	8.500	8.750	8.937	xxxxFFx12508500170xxx
-269	8.750	9.000	9.187	xxxxFFx12508750170xxx
-270	9.000	9.250	9.437	xxxxFFx12509000170xxx
-271	9.250	9.500	9.687	xxxxFFx12509250170xxx
-272	9.500	9.750	9.937	xxxxFFx12509500170xxx
-273	9.750	10.000	10.187	xxxxFFx12509750170xxx

Dash #	A Shaft Dia.	B Groove Dia.	C Flange C-Bore Dia. Min.	Part Number
-274	10.000	10.250	10.437	xxxxFFx12510000170xxx
-275	10.500	10.750	10.937	xxxxFFx12510500170xxx
-276	11.000	11.250	11.437	xxxxFFx12511000170xxx
-277	11.500	11.750	11.937	xxxxFFx12511500170xxx
-278	12.000	12.250	12.437	xxxxFFx12512000170xxx
-279	12.500	12.750	12.937	xxxxFFx12512500170xxx
-280	13.000	13.250	13.437	xxxxFFx12513000170xxx
-281	13.500	13.750	13.937	xxxxFFx12513500170xxx

R = 0.015" max. radius
 K = 0.057" Ref.
 G for Standard heel groove = 0.281/0.291" (260 callout)
 D Gland Counterbore depth for seal flange = 0.028/0.032"

	+0.00/-0.002	+0.002/-0.000		
-310	0.500	0.875	1.166	xxxxFFx18700500260xxx
-311	0.562	0.937	1.228	xxxxFFx18700562260xxx
-312	0.625	1.000	1.291	xxxxFFx18700625260xxx
-313	0.687	1.062	1.353	xxxxFFx18700687260xxx
-314	0.750	1.125	1.416	xxxxFFx18700750260xxx
-315	0.812	1.187	1.478	xxxxFFx18700812260xxx
-316	0.875	1.250	1.541	xxxxFFx18700875260xxx
-317	0.937	1.312	1.603	xxxxFFx18700937260xxx
-318	1.000	1.375	1.666	xxxxFFx18701000260xxx
-319	1.062	1.437	1.728	xxxxFFx18701062260xxx
-320	1.125	1.500	1.791	xxxxFFx18701125260xxx
-321	1.187	1.562	1.853	xxxxFFx18701187260xxx
-322	1.250	1.625	1.916	xxxxFFx18701250260xxx
-323	1.312	1.687	1.978	xxxxFFx18701312260xxx
-324	1.375	1.750	2.041	xxxxFFx18701375260xxx
-325	1.500	1.875	2.166	xxxxFFx18701500260xxx
-326	1.625	2.000	2.291	xxxxFFx18701625260xxx
-327	1.750	2.125	2.416	xxxxFFx18701750260xxx

02/15/08



Table 7-12. FF Flanged Inch/Fractional Gland Dimensions (Continued)

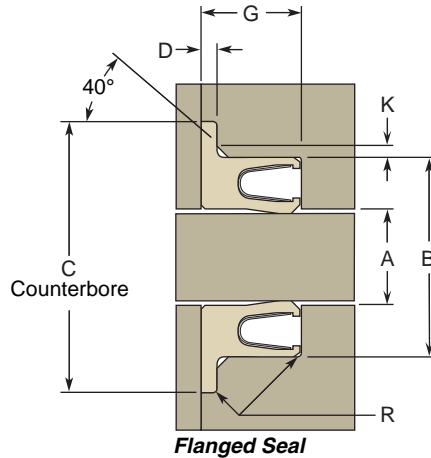

Dash #	A Shaft Dia.	B Groove Dia.	C Flange C-Bore Dia. Min.	Part Number
--------	--------------	---------------	---------------------------	-------------

R = 0.015" max. radius
 K = 0.057" Ref.
 G for Standard heel groove = 0.281/0.291" (260 callout)
 D Gland Counterbore depth for seal flange = 0.028/0.032"

	+0.000/ -0.002	+0.002/ -0.000		
-328	1.875	2.250	2.541	xxxxFFx18701875260xxx
-329	2.000	2.375	2.666	xxxxFFx18702000260xxx
-330	2.125	2.500	2.791	xxxxFFx18702125260xxx
-331	2.250	2.625	2.916	xxxxFFx18702250260xxx
-332	2.375	2.750	3.041	xxxxFFx18702375260xxx
-333	2.500	2.875	3.166	xxxxFFx18702500260xxx
-334	2.625	3.000	3.291	xxxxFFx18702625260xxx
-335	2.750	3.125	3.416	xxxxFFx18702750260xxx
-336	2.875	3.250	3.541	xxxxFFx18702875260xxx
-337	3.000	3.375	3.666	xxxxFFx18703000260xxx
-338	3.125	3.500	3.791	xxxxFFx18703125260xxx
-339	3.250	3.625	3.916	xxxxFFx18703250260xxx
-340	3.375	3.750	4.041	xxxxFFx18703375260xxx
-341	3.500	3.875	4.166	xxxxFFx18703500260xxx
-342	3.625	4.000	4.291	xxxxFFx18703625260xxx
-343	3.750	4.125	4.416	xxxxFFx18703750260xxx
-344	3.875	4.250	4.541	xxxxFFx18703875260xxx
-345	4.000	4.375	4.666	xxxxFFx18704000260xxx
-346	4.125	4.500	4.791	xxxxFFx18704125260xxx
-347	4.250	4.625	4.916	xxxxFFx18704250260xxx
-348	4.375	4.750	5.041	xxxxFFx18704375260xxx
-349	4.500	4.875	5.166	xxxxFFx18704500260xxx
-350	4.625	5.000	5.291	xxxxFFx18704625260xxx
-351	4.750	5.125	5.416	xxxxFFx18704750260xxx
-352	4.875	5.250	5.541	xxxxFFx18704875260xxx
-353	5.000	5.375	5.666	xxxxFFx18705000260xxx
-354	5.125	5.500	5.791	xxxxFFx18705125260xxx
-355	5.250	5.625	5.916	xxxxFFx18705250260xxx

Dash #	A Shaft Dia.	B Groove Dia.	C Flange C-Bore Dia. Min.	Part Number
-356	5.375	5.750	6.041	xxxxFFx18705375260xxx
-357	5.500	5.875	6.166	xxxxFFx18705500260xxx
-358	5.625	6.000	6.291	xxxxFFx18705625260xxx
-359	5.750	6.125	6.416	xxxxFFx18705750260xxx
-360	5.875	6.250	6.541	xxxxFFx18705875260xxx
-361	6.000	6.375	6.666	xxxxFFx18706000260xxx
-362	6.250	6.625	6.916	xxxxFFx18706250260xxx
-363	6.500	6.875	7.166	xxxxFFx18706500260xxx
-364	6.750	7.125	7.416	xxxxFFx18706750260xxx
-365	7.000	7.375	7.666	xxxxFFx18707000260xxx
-366	7.250	7.625	7.916	xxxxFFx18707250260xxx
-367	7.500	7.875	8.166	xxxxFFx18707500260xxx
-368	7.750	8.125	8.416	xxxxFFx18707750260xxx
-369	8.000	8.375	8.666	xxxxFFx18708000260xxx
-370	8.250	8.625	8.916	xxxxFFx18708250260xxx
-371	8.500	8.875	9.166	xxxxFFx18708500260xxx
-372	8.750	9.125	9.416	xxxxFFx18708750260xxx
-373	9.000	9.375	9.666	xxxxFFx18709000260xxx
-374	9.250	9.625	9.916	xxxxFFx18709250260xxx
-375	9.500	9.875	10.166	xxxxFFx18709500260xxx
-376	9.750	10.125	10.416	xxxxFFx18709750260xxx
-377	10.000	10.375	10.666	xxxxFFx18710000260xxx
-378	10.500	10.875	11.166	xxxxFFx18710500260xxx
-379	11.000	11.375	11.666	xxxxFFx18711000260xxx
-380	11.500	11.875	12.166	xxxxFFx18711500260xxx
-381	12.000	12.375	12.666	xxxxFFx18712000260xxx
-382	13.000	13.375	13.666	xxxxFFx18713000260xxx
-383	14.000	14.375	14.666	xxxxFFx18714000260xxx
-384	15.000	15.375	15.666	xxxxFFx18715000260xxx
-385	16.000	16.375	16.666	xxxxFFx18716000260xxx
-386	17.000	17.375	17.666	xxxxFFx18717000260xxx
-387	18.000	18.375	18.666	xxxxFFx18718000260xxx

02/15/08



Table 7-12. FF Flanged Inch/Fractional Gland Dimensions (Continued)

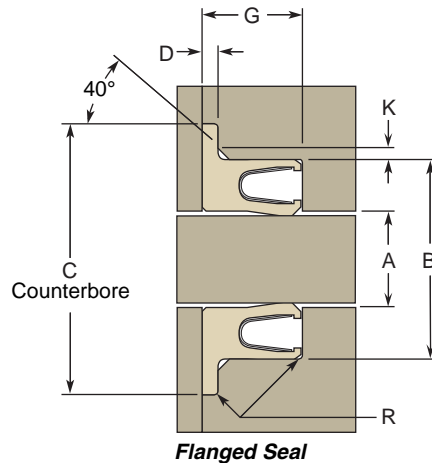

Dash #	A Shaft Dia.	B Groove Dia.	C Flange C-Bore Dia. Min.	Part Number
--------	--------------	---------------	---------------------------	-------------

R = 0.015" max. radius
 K = 0.057" Ref.
 G for Standard heel groove = 0.281/0.291" (260 callout)
 D Gland Counterbore depth for seal flange = 0.028/0.032"

	+0.000/ -0.002	+0.002/ -0.000		
-388	19.000	19.375	19.666	xxxxFFx18719000260xxx
-389	20.000	20.375	20.666	xxxxFFx18720000260xxx
-390	21.000	21.375	21.666	xxxxFFx18721000260xxx
-391	22.000	22.375	22.666	xxxxFFx18722000260xxx
-392	23.000	23.375	23.666	xxxxFFx18723000260xxx
-393	24.000	24.375	24.666	xxxxFFx18724000260xxx
-394	25.000	25.375	25.666	xxxxFFx18725000260xxx
-395	26.000	26.375	26.666	xxxxFFx18726000260xxx

R = 0.015" max. radius
 K = 0.069" Ref.
 G for Standard heel groove = 0.375/0.385" (355 callout)
 D Gland Counterbore depth for seal flange = 0.041/0.045"

	+0.000/ -0.002	+0.002/ -0.000		
-401	1.500	2.000	2.322	xxxxFFx25001500355xxx
-402	1.625	2.125	2.447	xxxxFFx25001625355xxx
-403	1.750	2.250	2.572	xxxxFFx25001750355xxx
-404	1.875	2.375	2.697	xxxxFFx25001875355xxx
-405	2.000	2.500	2.822	xxxxFFx25002000355xxx
-406	2.125	2.625	2.947	xxxxFFx25002125355xxx
-407	2.250	2.750	3.072	xxxxFFx25002250355xxx
-408	2.375	2.875	3.197	xxxxFFx25002375355xxx
-409	2.500	3.000	3.322	xxxxFFx25002500355xxx
-410	2.625	3.125	3.447	xxxxFFx25002625355xxx
-411	2.750	3.250	3.572	xxxxFFx25002750355xxx
-412	2.875	3.375	3.697	xxxxFFx25002875355xxx
-413	3.000	3.500	3.822	xxxxFFx25003000355xxx
-414	3.125	3.625	3.947	xxxxFFx25003125355xxx
-415	3.250	3.750	4.072	xxxxFFx25003250355xxx
-416	3.375	3.875	4.197	xxxxFFx25003375355xxx

Dash #	A Shaft Dia.	B Groove Dia.	C Flange C-Bore Dia. Min.	Part Number
-417	3.500	4.000	4.322	xxxxFFx25003500355xxx
-418	3.625	4.125	4.447	xxxxFFx25003625355xxx
-419	3.750	4.250	4.572	xxxxFFx25003750355xxx
-420	3.875	4.375	4.697	xxxxFFx25003875355xxx
-421	4.000	4.500	4.822	xxxxFFx25004000355xxx
-422	4.125	4.625	4.947	xxxxFFx25004125355xxx
-423	4.250	4.750	5.072	xxxxFFx25004250355xxx
-424	4.375	4.875	5.197	xxxxFFx25004375355xxx
-425	4.500	5.000	5.322	xxxxFFx25004500355xxx
-426	4.625	5.125	5.447	xxxxFFx25004625355xxx
-427	4.750	5.250	5.572	xxxxFFx25004750355xxx
-428	4.875	5.375	5.697	xxxxFFx25004875355xxx
-429	5.000	5.500	5.822	xxxxFFx25005000355xxx
-430	5.125	5.625	5.947	xxxxFFx25005125355xxx
-431	5.250	5.750	6.072	xxxxFFx25005250355xxx
-432	5.375	5.875	6.197	xxxxFFx25005375355xxx
-433	5.500	6.000	6.322	xxxxFFx25005500355xxx
-434	5.625	6.125	6.447	xxxxFFx25005625355xxx
-435	5.750	6.250	6.572	xxxxFFx25005750355xxx
-436	5.875	6.375	6.697	xxxxFFx25005875355xxx
-437	6.000	6.500	6.822	xxxxFFx25006000355xxx
-438	6.250	6.750	7.072	xxxxFFx25006250355xxx
-439	6.500	7.000	7.322	xxxxFFx25006500355xxx
-440	6.750	7.250	7.572	xxxxFFx25006750355xxx
-441	7.000	7.500	7.822	xxxxFFx25007000355xxx
-442	7.250	7.750	8.072	xxxxFFx25007250355xxx
-443	7.500	8.000	8.322	xxxxFFx25007500355xxx
-444	7.750	8.250	8.572	xxxxFFx25007750355xxx
-445	8.000	8.500	8.822	xxxxFFx25008000355xxx
-446	8.500	9.000	9.322	xxxxFFx25008500355xxx
-447	9.000	9.500	9.822	xxxxFFx25009000355xxx
-448	9.500	10.000	10.322	xxxxFFx25009500355xxx
-449	10.000	10.500	10.822	xxxxFFx25010000355xxx
-450	10.500	11.000	11.322	xxxxFFx25010500355xxx

02/15/08



Table 7-12. FF Flanged Inch/Fractional Gland Dimensions (Continued)

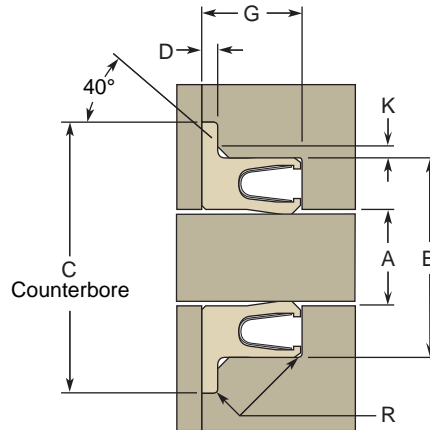

Flanged Seal

Dash #	A Shaft Dia.	B Groove Dia.	C Flange C-Bore Dia. Min.	Part Number
--------	--------------	---------------	---------------------------	-------------

R = 0.015" max. radius
 K = 0.069" Ref.
 G for Standard heel groove = 0.375/0.385" (355 callout)
 D Gland Counterbore depth for seal flange = 0.041/0.045"

	+0.001/ -0.002	+0.002/ -0.000		
-451	11.000	11.500	11.822	xxxxFFx25011000355xxx
-452	11.500	12.000	12.322	xxxxFFx25011500355xxx
-453	12.000	12.500	12.822	xxxxFFx25012000355xxx
-454	12.500	13.000	13.322	xxxxFFx25012500355xxx
-455	13.000	13.500	13.822	xxxxFFx25013000355xxx
-456	13.500	14.000	14.322	xxxxFFx25013500355xxx
-457	14.000	14.500	14.822	xxxxFFx25014000355xxx
-458	14.500	15.000	15.322	xxxxFFx25014500355xxx
-459	15.000	15.500	15.822	xxxxFFx25015000355xxx
-460	15.500	16.000	16.322	xxxxFFx25015500355xxx

Dash #	A Shaft Dia.	B Groove Dia.	C Flange C-Bore Dia. Min.	Part Number
-461	16.000	16.500	16.822	xxxxFFx25016000355xxx
-462	16.500	17.000	17.322	xxxxFFx25016500355xxx
-463	17.000	17.500	17.822	xxxxFFx25017000355xxx
-464	17.500	18.000	18.322	xxxxFFx25017500355xxx
-465	18.000	18.500	18.822	xxxxFFx25018000355xxx
-466	18.500	19.000	19.322	xxxxFFx25018500355xxx
-467	19.000	19.500	19.822	xxxxFFx25019000355xxx
-468	19.500	20.000	20.322	xxxxFFx25019500355xxx
-469	20.000	20.500	20.822	xxxxFFx25020000355xxx
-470	21.000	21.500	21.822	xxxxFFx25021000355xxx
-471	22.000	22.500	22.822	xxxxFFx25022000355xxx
-472	23.000	23.500	23.822	xxxxFFx25023000355xxx
-473	24.000	24.500	24.822	xxxxFFx25024000355xxx
-474	25.000	25.500	25.822	xxxxFFx25025000355xxx
-475	26.000	26.500	26.822	xxxxFFx25026000355xxx



02/15/08



FlexiSeal® Rotary Seals

FF Profiles — Flanged Metric

Catalog EPS 5340/USA



Flanged FlexiSeal

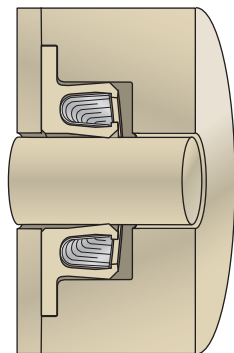

Flanged Rotary Application

Metric FF Profiles

FF FlexiSeal Rotary Shaft, Flanged profiles are clamped axially in the gland to ensure that the seal does not spin with the shaft, especially in applications with frequent thermal cycling.

Design Considerations

- Hardware Configurations/Installation, see **Page 2-3**
- Surface Finish and Hardness, see **Page 2-9**
- Extrusion Gaps and High Pressure, see **Page 2-10**
- Spring Choices, see **Page 2-12**
- Lip Shapes, see **Page 2-16**
- Rotary Seal Considerations, see **Page 2-17**
- Shaft Misalignment Issues, see **Page 2-19**

Part Number Example

Table 7-13. FF Flanged Metric Part Number

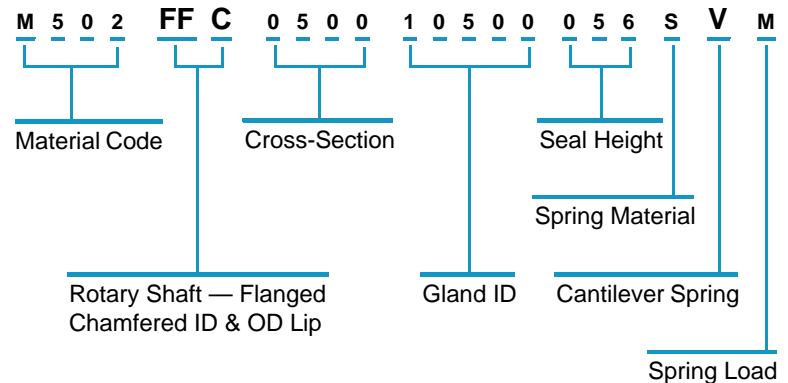

7

01/15/06



Gland Dimensions — FF Profiles, Flanged Metric

Table 7-14. FF Flanged Metric Gland Dimensions

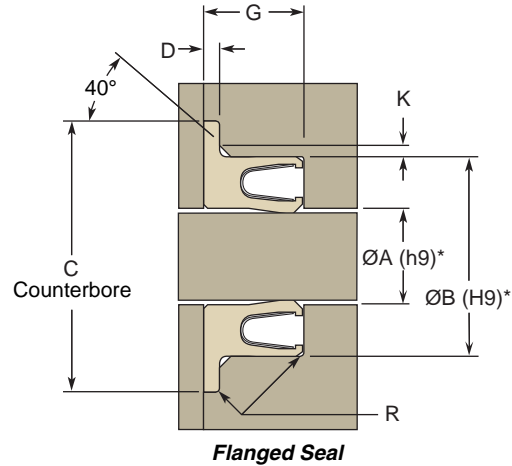

Each of these FlexiSeal profiles were designed to fit into the Metric glands on this page.

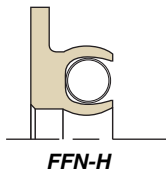
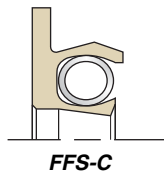
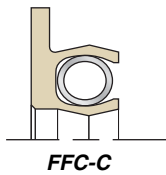
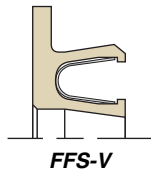
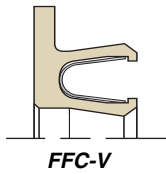

Cross-Section Callout	Gland Cross-Section	Heel Height Callout	Heel Groove Width (G) +0.25/-0.00 mm	Counter Bore Depth (D)	Counter Bore Min. Dia. (C)	Chamfer Size (K)	Max Radius (R)
0200	2.00 mm	021	2.39 mm	0.28/ 0.33 mm	ØA + 7.81 mm	0.43 mm	0.18 mm
0250	2.50 mm	033	3.58 mm	0.43/ 0.51 mm	ØA + 8.94 mm	0.71 mm	0.25 mm
0400	4.00 mm	043	4.78 mm	0.61/ 0.69 mm	ØA + 12.75 mm	1.02 mm	0.25 mm
0500	5.00 mm	066	7.14 mm	0.71/ 0.81 mm	ØA + 17.39 mm	1.45 mm	0.38 mm
0700	7.00 mm	090	9.53 mm	1.04/ 1.14 mm	ØA + 22.18 mm	1.75 mm	0.38 mm

* For ISO Tolerances see **Appendix D**.
 ** See **Page 2-10** for more on extrusion gap.

Example Part Numbers

Part Number	Shaft Ø (A) in mm	Groove Ø (B) in mm	Counter-Bore Ø (C) in mm	Counter-Bore Depth (D) in mm	Groove Width (G) in mm
FFC-V Profile					
M100FFC070012500090SVL	125.00 +0.00/-0.10	139.00 +0.10/-0.00	147.18 Min.	1.04/1.14	9.53 +0.25/-0.00
FFS-C Profile					
M301FFS020001100021HCH	11.00 +0.00/-0.04	15.00 +0.04/-0.00	18.81 Min.	0.28/0.33	2.39 +0.25/-0.00



02/15/08